



2011/65/EU, (EU)2015/863
10 Substances regulation compliant



Lead-free solder heat resistant product



Features

Package	Bi-color emitting product, Milky white resin, Emitting color : Yellow green / Red Outline dimensions : 1.6 x 1.5 x 0.7mm (L x W x H)
Product features	<ul style="list-style-type: none">·Wide temperature range usage is available·Lead-free soldering compatible·RoHS:2011/65/EU, (EU)2015/863 compliant·5mA drive

Recommended applications

·Communication machine, electric household appliances, OA/FA, other general applications

Outline dimensions

FRYPY1211C-0005-TR

Unit : mm
 Weight : 3.0mg
 Tolerance : ±0.1

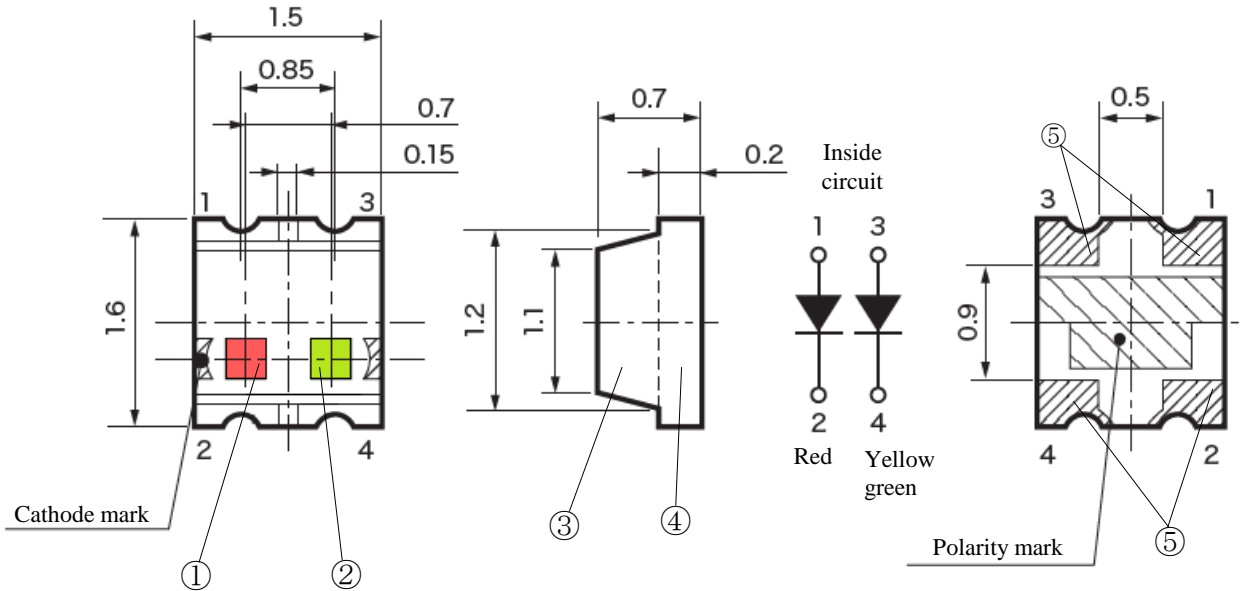

No.	Part name	Material	Qty.
①	LED die (Red)	AlGaInP	1
②	LED die (Yellow green)	AlGaInP	1
③	Mold resin	Epoxy resin	1
④	PCB	Glass fabrics	1
⑤	Electrode	Au/Ni/Cu	Anode:2 Cathode:2

Note : The cutting burr size of the substrate and pin isn't contained in the size of the height of the product.

Recommended soldering pattern

Unit : mm

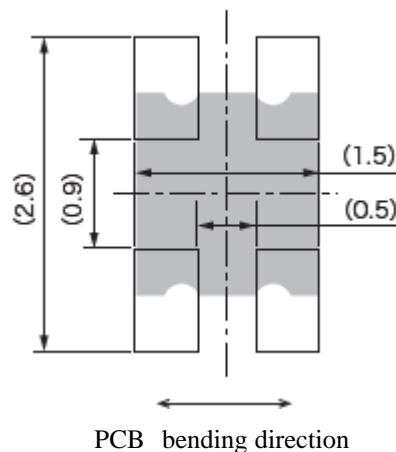

【 Product overview 】

Die material	AlGaInP
Emitting color	Yellow green / Red
Resin color (Emitting area)	Milky white

【 Absolute maximum ratings 】

(Ta=25°C)

ITEM	SYMBOL	MAXIMUM RATINGS		UNITS
		FR (Red)	YPY (Yellow green)	
Power dissipation	P_d	36	36	mW
Forward current	I_F	15	15	mA
Repetitive peak forward current "1ms,1/20duty"	I_{FRM}	48	48	mA
I_F Derate linearly from "Ta=25°C"	ΔI_F	0.21	0.21	mA/°C
I_{FRM} Derate linearly from "Ta=25°C"	ΔI_{FRM}	0.69	0.69	mA/°C
Reverse voltage	V_R	5	5	V
Operating temperature	T_{opr}	-40 to +85		°C
Storage temperature	T_{stg}	-40 to +85		°C
Soldering temperature "Reflow soldering"	T_{sld}	260		°C

Notes 1

Notes1 Please refer to the attached sheets page 9, Soldering conditions.

- ※ The ratings specified above are under the condition that only one diode is lit.
50% Max. of each rating shall be applied when two diodes are lit simultaneously.

【Electro-Optical characteristics】

(Ta=25°C)

ITEM	SYMBOL	CONDITIONS	CHARACTERISTICS		UNIT	
			FR	YPY		
Forward voltage	V _F	I _F =5mA	Typ.	1.85	1.95	V
			Max.	2.4	2.4	
Reverse current	I _R	V _R =5V	Max.	100	100	μA
Peak wavelength	λ _p	I _F =5mA	Typ.	635	572	nm
Dominant wavelength	λ _d	I _F =5mA	Typ.	626	570	nm
Spectral line half width	Δλ	I _F =5mA	Typ.	15	15	nm
Half intensity angle	2θ _{1/2}	I _F =5mA	Typ. (θ _x)	115	115	deg.
			Typ. (θ _y)	140	140	

Note Above the table of luminous intensity (I_v) values and dominant wavelength (λ_d) values are the setup value of the selection machine. 【Tolerance : I_v...±10%, λ_d...±1nm】

【Sorting for Luminous intensity and Dominant wavelength】

LEDs shall be sorted out into the following ranks of Luminous intensity and Dominant wavelength.

Luminous intensity (I_v) rank

Rank	I _v (mcd)				CONDITIONS
	FR		YPY		
	Min.	Max.	Min.	Max.	
AA	14.0	22.0	6.3	10.0	I _F =5mA Ta=25°C
AB	14.0	22.0	10.0	16.0	
AC	14.0	22.0	16.0	25.0	
BA	22.0	36.0	6.3	10.0	
BB	22.0	36.0	10.0	16.0	
BC	22.0	36.0	16.0	25.0	
CA	36.0	57.0	6.3	10.0	
CB	36.0	57.0	10.0	16.0	
CC	36.0	57.0	16.0	25.0	

Dominant wavelength (λ_d) rank

Rank	λ _d (nm)		CONDITIONS
	YPY		
	MIN.	MAX.	
A	566.5	570.0	I _F =5mA Ta=25°C
B	570.0	574.5	

Note Above the table of luminous intensity (I_v) values and dominant wavelength (λ_d) values are the setup value of the selection machine. 【Tolerance : I_v...±10%, λ_d...±1nm】

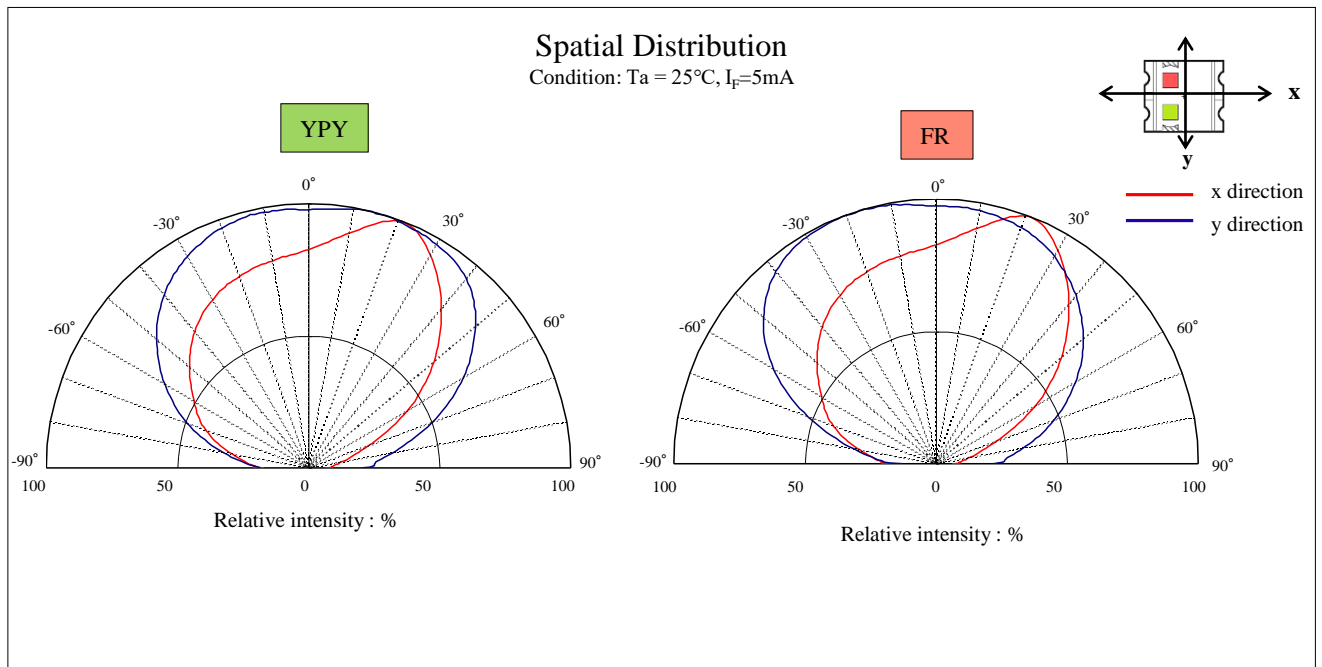
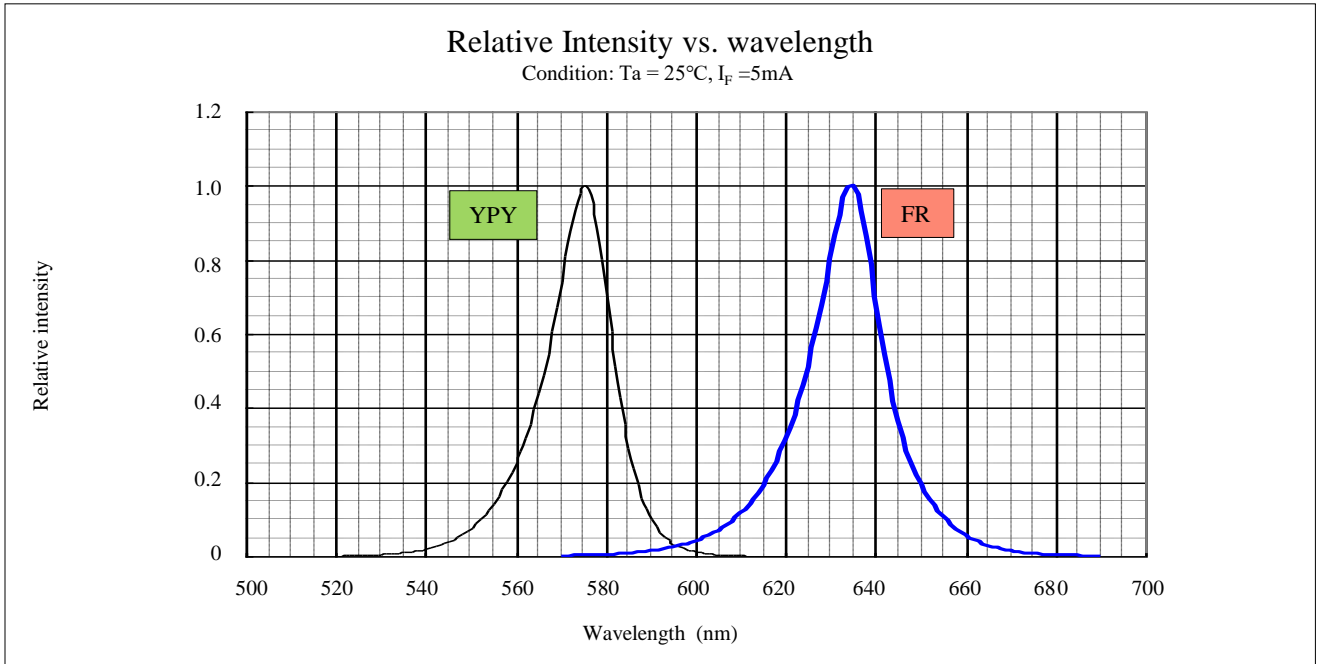

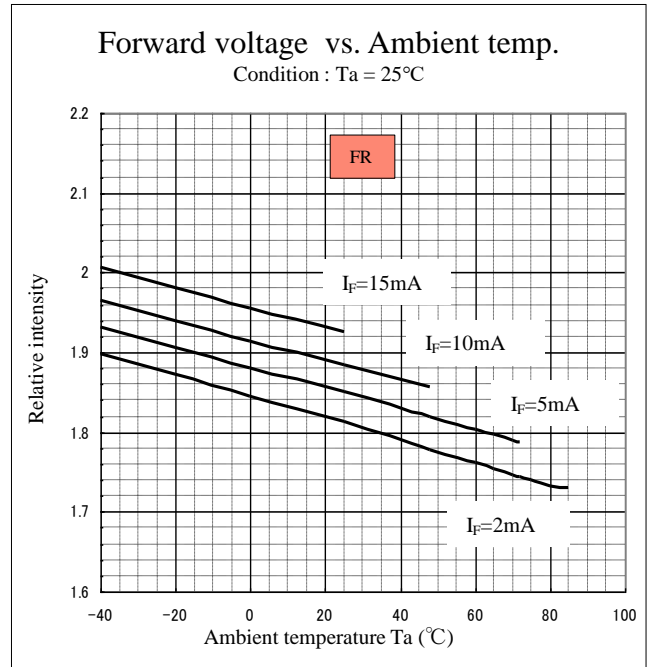
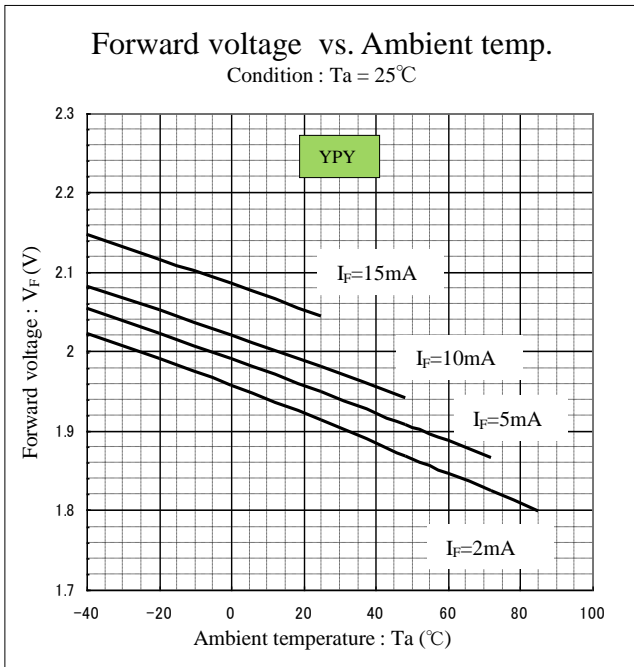
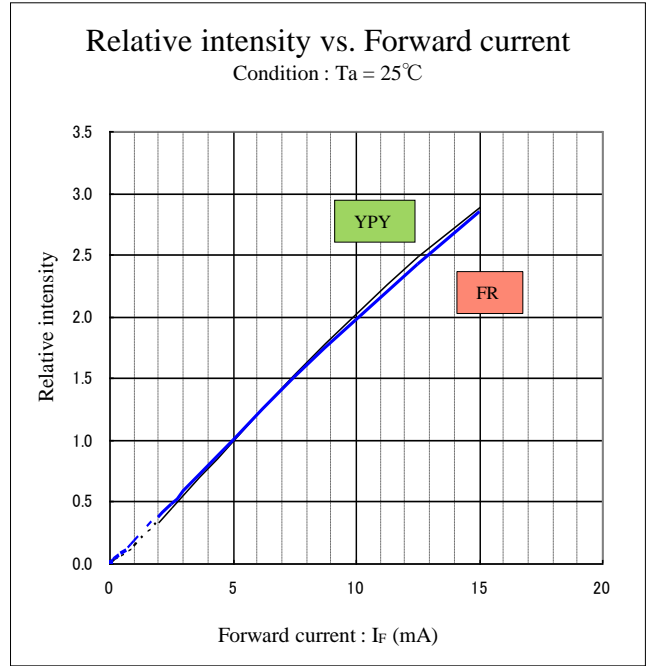
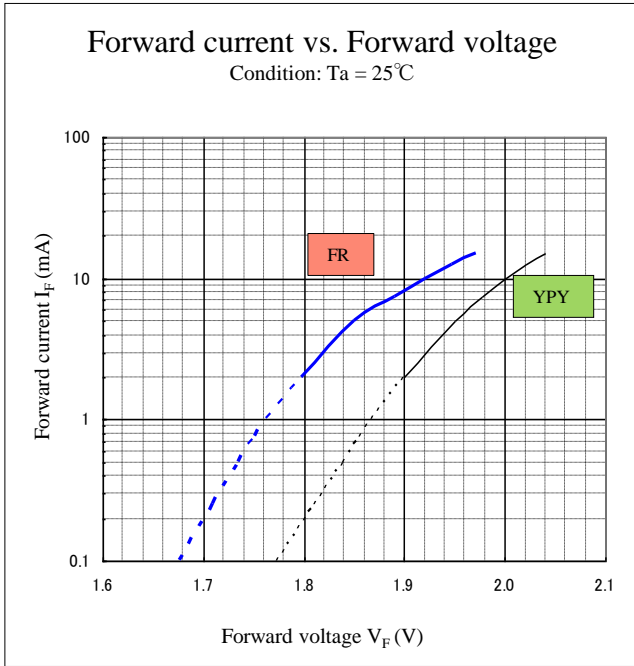

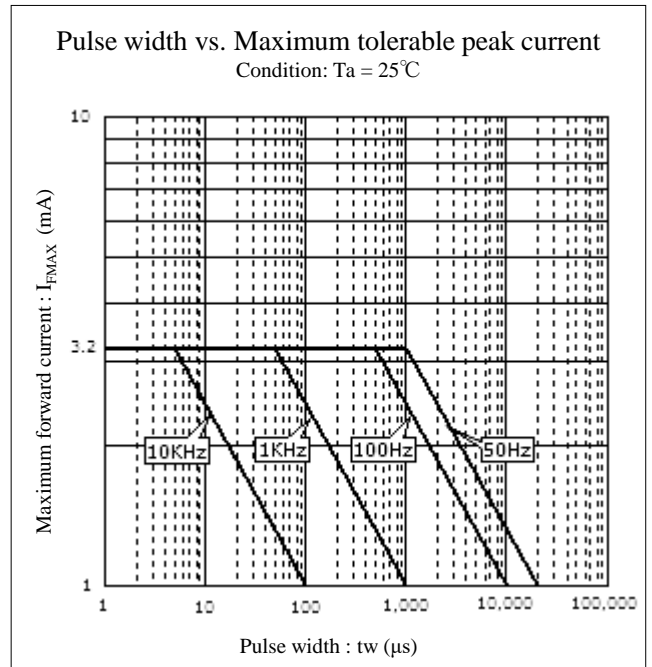
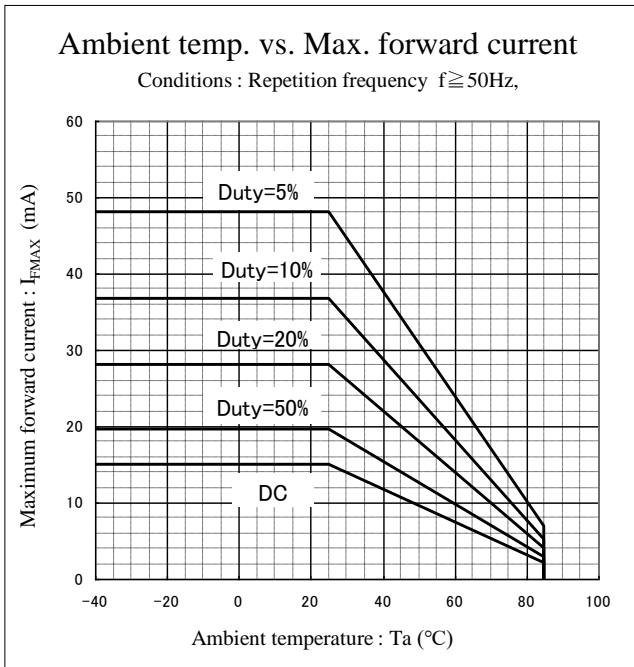
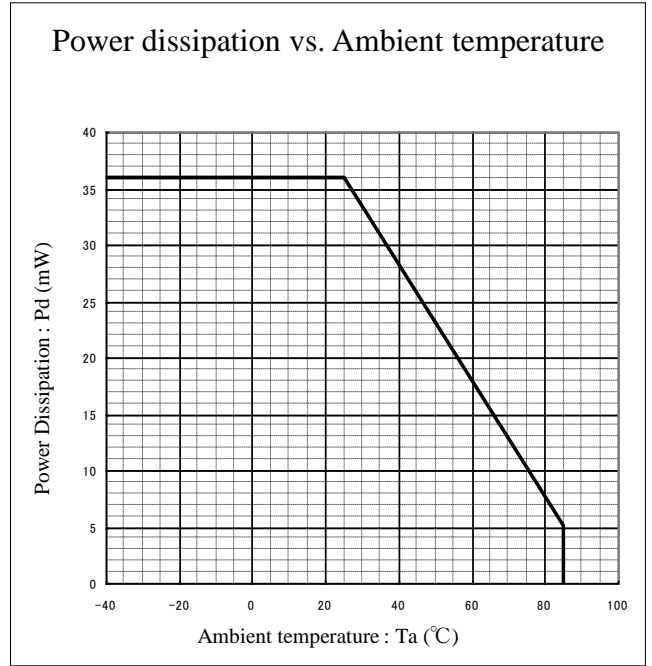
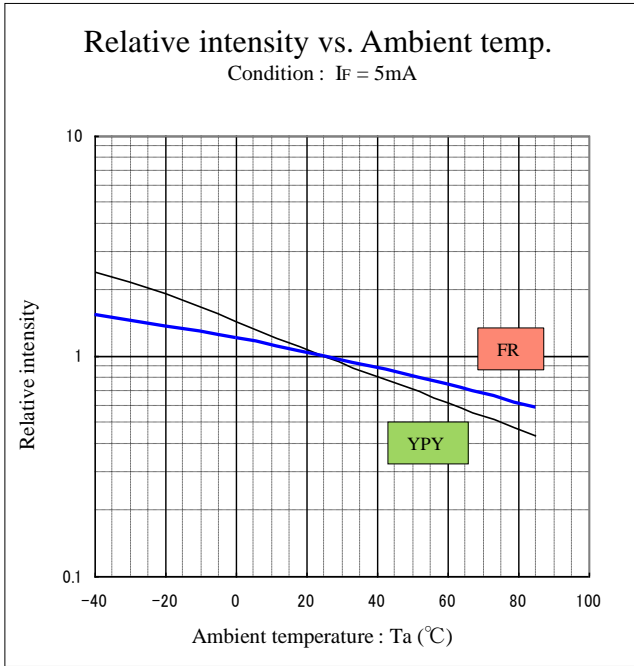

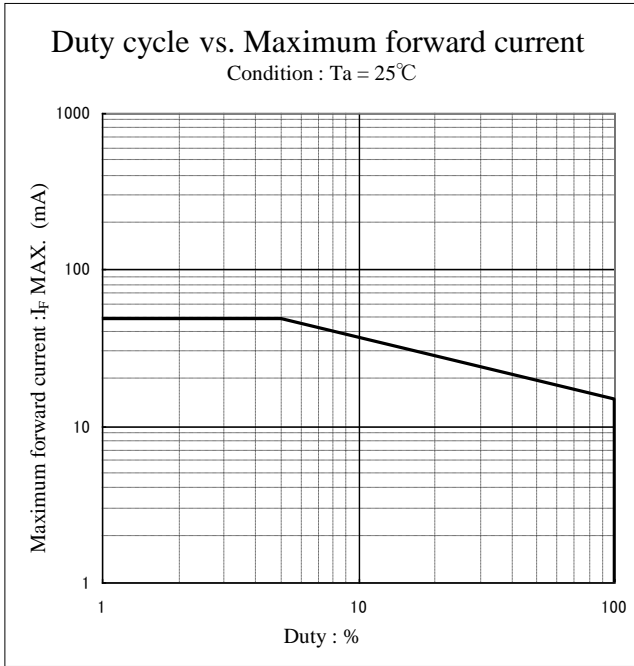

【Soldering precaution】

(acc.to EIAJ-4701/300)

1. Heat stress during soldering will influence the reliability of LEDs, however that effect will vary on heating method. Also, if components of varying shape are soldered together, it is recommended to set the soldering pad temperature according to the component most vulnerable to heat (e.g., surface mount LED).
2. LED parts including the resin are not stable immediately after soldering (when they are not at room temperature), any mechanical stress may cause damage to the product. Please avoid such stress after soldering, especially stacking of the boards which may cause the boards to warp and any other types of friction with hard materials.
3. Recommended temperature profile for the Reflow soldering is listed as the temperature of the resin surface. Temperature distribution varies on heating method, PCB material, other components in the assembly, and mounting density .
Please do not repeat the heating process in Reflow process more than 2times.

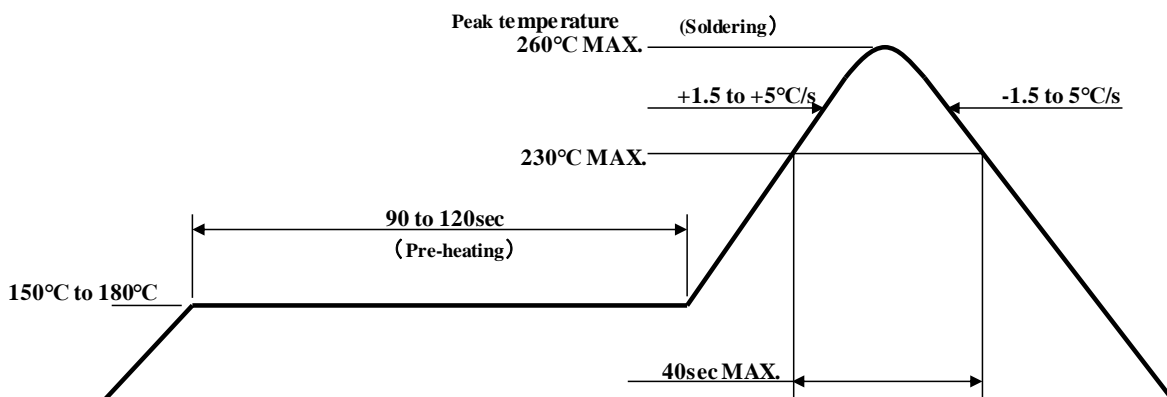
【Recommended reflow soldering condition】

Notes 1

Temperature Profile for the reflow should be set to the surface temperature of resin which is on the top of LED. This should be the maximum temperature for soldering. Lowering the heating temperature and decreasing heating time is very effective in achieving higher reliability.

Notes 2

The reflow soldering process should be done up to twice(2 times Max). When second process is performed, interval between first and second process should be as short as possible to prevent absorption of moisture to resin of LED. The second soldering process should not be done until LEDs have returned to room temperature (by nature-cooling) after first soldering process.

4. If soldering manually, Stanley recommends using a soldering iron equipped with temperature control. During the actual soldering process, make sure that the soldering iron never touches the device itself, and avoid the device's electrode temperature reaching above the temperature of the solder pad. All repairs must be performed only once in the same place, and please avoid reusing components.
5. During the soldering process with a soldering iron, if the iron, tip has been cleaned, please make sure that the soldering iron reaches the appropriate temperature before resuming the solder process. Also, please avoid applying any types of pressure to the soldered components while the solder is cooling and hardening, as it may influence solder performance and solder quality.

【Recommended manual soldering condition】

Temperature of iron tip	350°C MAX.
Soldering duration, time	3sec.Max., 1 time

6. When using adhesive material for tentative fixatives, thermosetting resin or Ultraviolet radiation(UV) setting resin with heat shall be recommended.《The curing condition, Temperature:150°CMax./Time:120sec.Max.》
7. When cleaning, isopropyl alcohol shall be recommended. Some chemicals, including Freon substitute detergent could corrode or affect the optical characteristics of the lens or the casing surface. Please review the reference chart below for cleaning. Cleani

Cleaning agents	Recommended / Not recommended
Isopropyl alcohol	✓ Recommended
Ethyl alcohol	✓ Recommended
Pure water	✓ Recommended
Trichloroethylene	x Not recommended
Chloroethene	x Not recommended
Acetone	x Not recommended
Thinner	x Not recommended

8. This products should not be recommended flow soldering(dip soldering).

【Other precautions】

1. The products are designed to achieve higher performance reliability, however, they can be influenced by usage conditions.
2. Absolute maximum ratings are set to prevent LED products from failing due to excess stress (temperature, current, voltage, etc.). These ratings must never be overrun even for a moment.
3. To achieve the highest performance reliability, it is necessary to take into account, factors such as forward voltage adjusted to the usage temperature condition, derating of the power consumption, and other variable factors.
4. Please insert Straight Protective Resistors into the circuit in order to stabilize LED operation and to prevent the device from igniting due to excess current.
5. Please check the actual performance in the assembly because the Specification Sheets are described for LED device only.
6. Please refrain from looking directly at the light source of LED at high output, as it may harm your vision.
7. The products are designed to operate without failure in recommended usage conditions. However, please take the necessary precautions to prevent fire, injury, and other damages should any malfunction or failure arise.
8. The products are manufactured to be used for ordinary electronic equipment. Please contact our sales staff beforehand when exceptional quality and reliability are required, and the failure or malfunction of the products might directly jeopardize life or health (such as for airplanes, aerospace, transport equipment, medical applications, nuclear reactor control systems and so on)..
9. The formal specification sheets shall be valid only by exchange of documents by both parties.

This products are baked (moisture removal) before packaging, and are shipped in moisture-proof packaging (as shown below) to minimize moisture absorption during transportation.

However, in regards to storing the products, the use of dry-box under the following conditions is recommended. Moisture-proof bag as the packaging is made of anti-static material but packaging box is not.

【Recommended storage condition / Products warranty period】

Temperature	+5~30°C
Humidity	Under 70%

In the case of the package unopened , **6 months** under 【 Recommended Storage Condition 】. Please avoid rapid transition from low temp. condition to high temp. condition and storage in corroding and dusty environment.

【Time elapsed after package opening】

The package should not be opened until immediately prior to its use, and please keep the time frame between package opening and soldering which is **【maximum 72h.】** If the device needs to be soldered twice, both soldering must be completed within 72h.

If any components should remain after their use, please seal the package and store them under the conditions Described in the 【 Recommended Storage Condition 】.

The product must be required to perform baking process (moisture removal) for **at least 10h and not exceed for 12h , at 60+/-5 degrees C** if following conditions apply.

1. In the case of color of indicators (those are in the package of desiccant) change or lose its blue color.
2. In the case of time is passed for 672h after the package is opened once.

Please backing process must be performed after putting out from package.

Baking may be performed in the tape-reel form, however if it is performed with the reel stacked over one another, it may cause deformation of the reels and taping materials, which may cause problems during production. Please make sure that the product has cooled to normal temperature after performing the baking process. Provided that, baking process shall be 2 times MAX.

【Moisture-proof packaging specification】

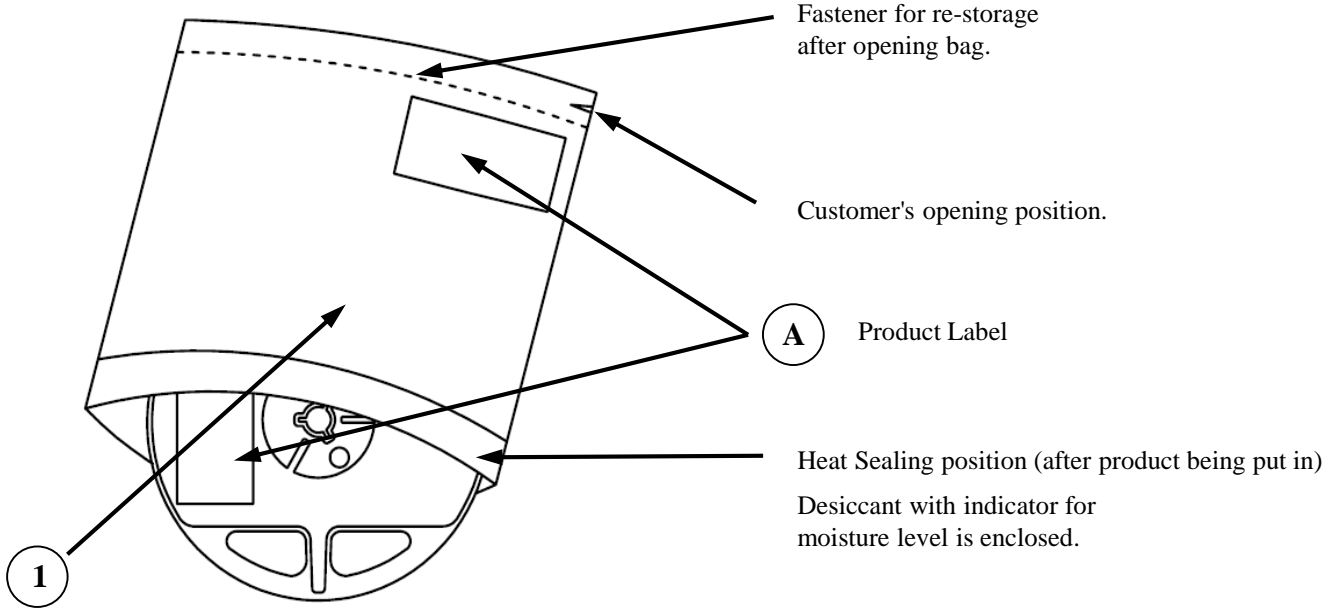

NO.	PART NAME	MATERIALS	REMARKS
①	Moisture-proof bag with Aluminum layer	PET+Al+PE	with ESD protection

【Flow chart-package opening to mounting】

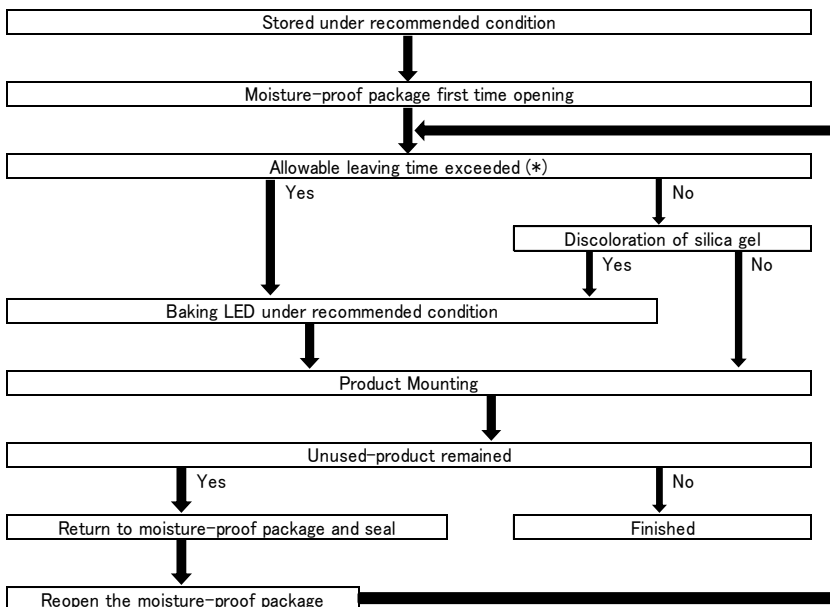

Allowable leaving time means the maximum allowable leaving time after opening package, which depends on each LED type. The allowable leaving time should be calculated from the first opening of package to the time when soldering process is finished. When judging if the allowable leaving time has exceeded or not, please subtract the soldering time. The allowable leaving time after reopening should be calculated from the first opening of package, or from the time when baking process is finished.

【 Packing box 】

(RoHS / ELV compliant)

Box type	Outline dimension L × W × H (mm)	Capacity of the box
Type A	280 × 265 × 45	3 reels
Type B	310 × 235 × 265	15 reels
Type C	440 × 310 × 265	30 reels
Type D	305 × 270 × 65	3 reels
Type E	370 × 280 × 270	30 reels
Type F	530 × 380 × 270	60 reels

The above measurements are reference values.

The box is selected out of the above table by shipping quantity.

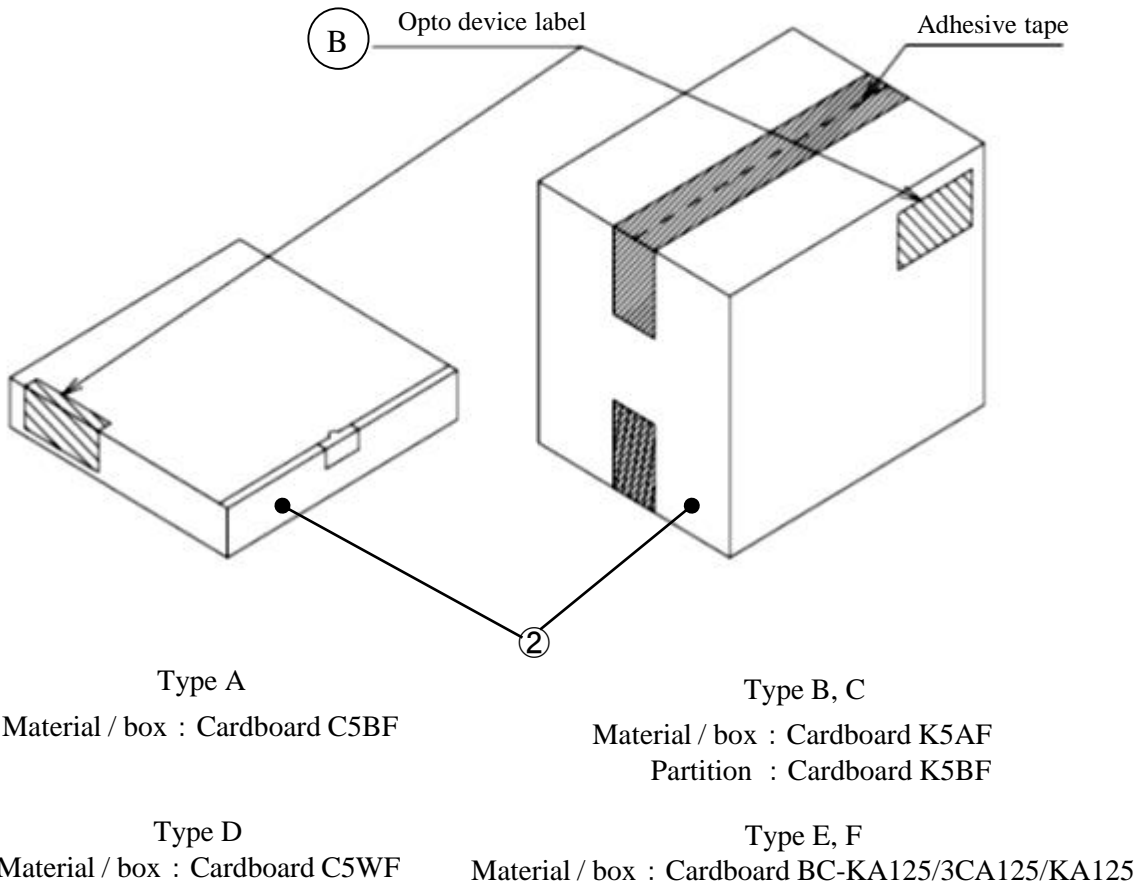

No.	Part name	Material	Remarks
②	Packing box	Corrugated Cardboard	without ESD protection

(acc.to JIS-X0503(Code-39))

【Label specification】

A Product label

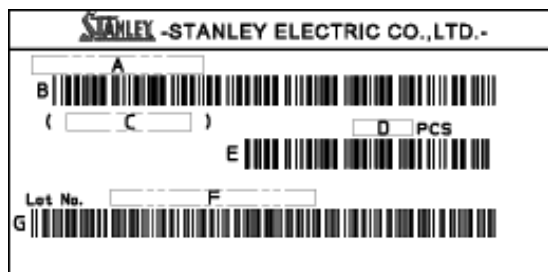

- A. Parts number
- B. Bar-code for parts number
- C. Parts code (In-house identification code for each parts number)
- D. Packed parts quantity
- E. Bar-Code for packed parts quantity
- F. Lot number & rank
- (Please refer to Lot number notational system for details)
- G. Bar-code for Lot number & rank

B Opto device label

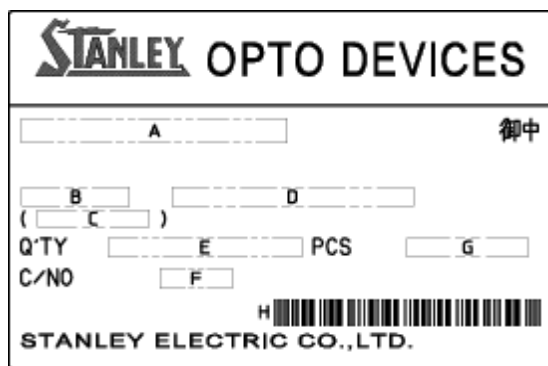

- A. Customer name
- B. Parts type
- C. Parts code
- D. Parts number
- E. Packed parts quantity
- F. Carton number
- G. Shipping date
- H. Bar-code for in-house identification number

<Remarks> Bar-code font : acc.to Code-39(JIS-X0503)

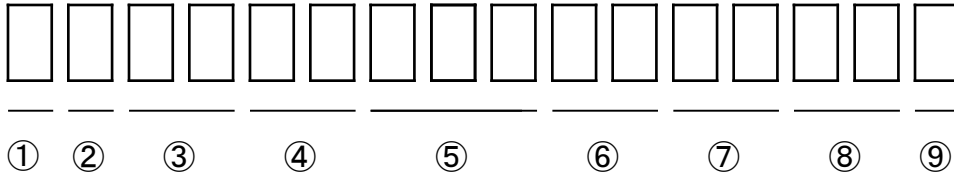

① - 1digit : Production location (Mark identify by alphabet)

② - 1digit : Production year(The last digit of production year 2025→5, 2026→6, 2027→7, 2028→8 ...)

③ - 2digits : Production month (Jan. to Sep. , should be 01, 02, 03,.....)

④ - 2digits : Production date

⑤ - 3digits : Serial number

⑥ - 2digits : Tape and reel following number

⑦ - 2digits : Luminous intensity rank.

(If luminous intensity rank is 1 digit, "-" shall be dashed on the place for the second digit.
If there is no identified intensity rank, "- -" is used to indicate.)

⑧ - 2digits : Color / Chromaticity rank

(If color / chromaticity rank is 1 digit, "-" shall be dashed on the place for the second digit.
If there is no identified intensity rank, "- -" is used to indicate.)

⑨ - 1digit : Option rank (Stanley normally print "-" to indicate)

(acc.to JIS-C0806-03)

【Appearance】

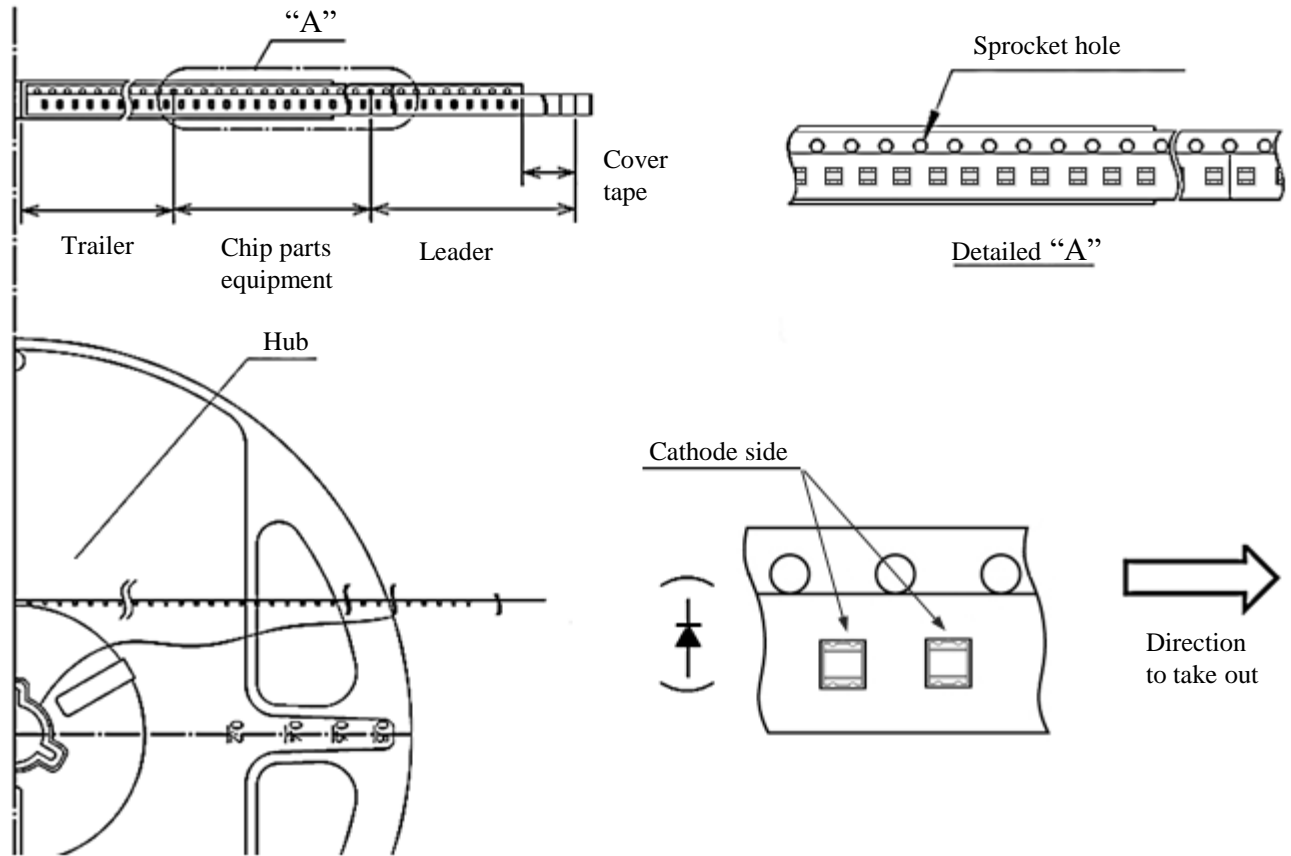

Note

"-TR" means Cathode Side of LEDs should be placed on the sprocket-hole side.

Items		Specifications	Remarks
Leader area	Cover-tape	Cover-tape shall be longer than 200mm without carrier-tape	The end of cover-tape shall be held with adhesive tape.
	Carrier-tape	Empty pocket shall be more than 10 pieces.	Please refer to the above figure for Taping & reel orientation .
Trailer area		Empty pocket shall be more than 15 pieces.	The end of taping shall be inserted into a slit of the hub.

(acc.to JIS-C0806-03)

【 Qty. per Reel】

4,000 parts/reel

※ Minimum Qty. per reel might be 500 parts when getting less than 4,000 parts.

In such case, parts of 500-unit-qty. shall be packed in a reel and the qty. shall be identified on the label.

【Mechanical strength】

Cover-tape adhesive strength shall be 0.1~1.0N (An angle between carrier-tape and cover-tape shall be 170 deg.).

Both tapes shall be so sealed that the contained parts will not come out from the tape when it is bent at a radius of 15mm.

【 Others】

- Reversed-orientation, Up-side down placing, side placing and out of spec. parts mix shall not be held.
- The number of empty pockets within a reel is made into 5pcs. or less and no more than 1 connecting empty pockets of taping.

(acc.to JIS-C0806-03)

Unit :mm

【Taping dimensions】

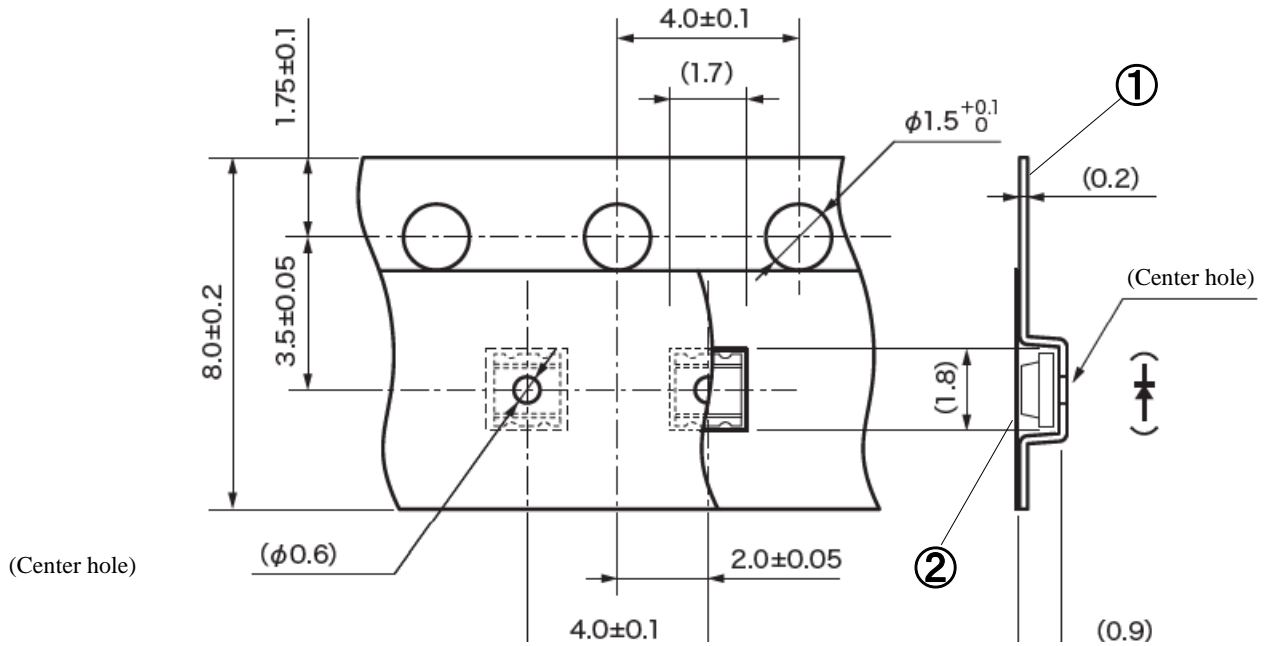

【Reel dimensions】

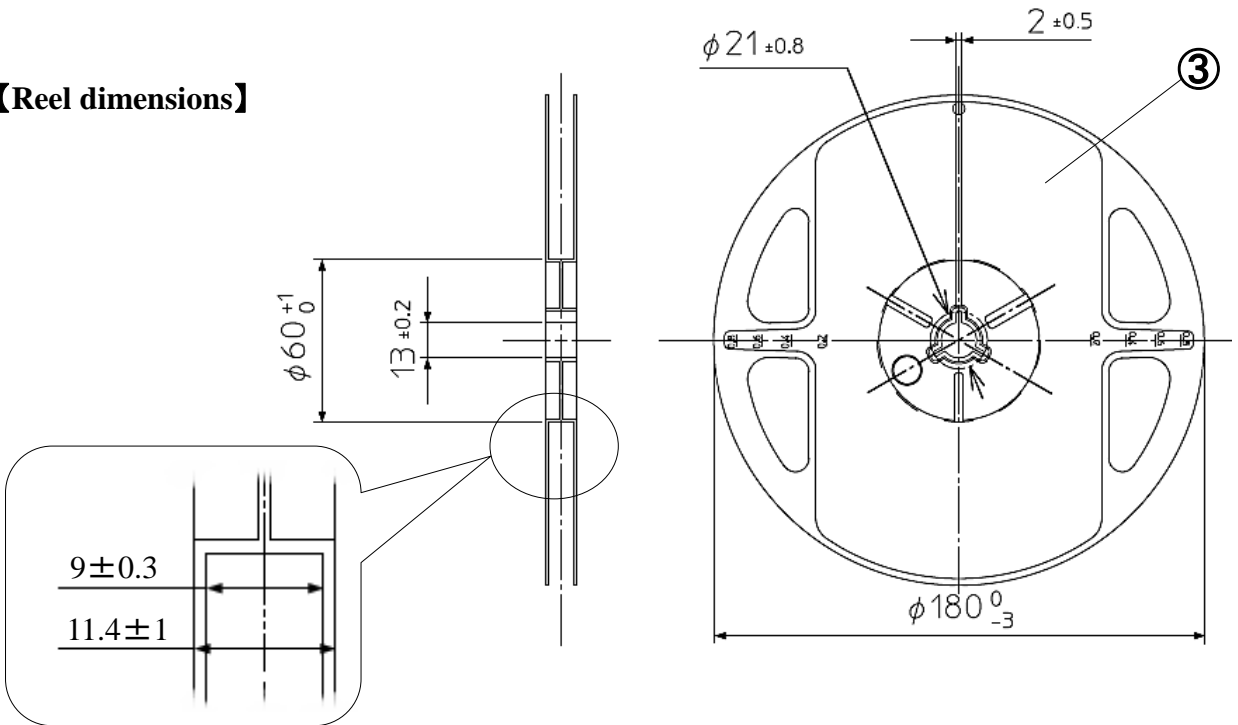

No.	Part name	Remarks
①	Carrier tape	with ESD protection
②	Cover tape	with ESD protection
③	Carrier reel	with ESD protection

This product is in compliance with RoHS / ELV.

Prohibition substance and its criteria value of RoHS / ELV are as follows.

- RoHS instruction ... Refer to following 1 to 10.
- ELV instruction ... Refer to following 1 to 4.

2011/65/EU, (EU)2015/863

No.	Substance group name	Maximum permissible concentration value
1	Lead and its compounds	1,000ppm (0.1%)
2	Cadmium and its compounds	100ppm (0.01%)
3	Mercury and its compounds	1,000ppm (0.1%)
4	Hexavalent chromium compounds	1,000ppm (0.1%)
5	PBB : Polybrominated Biphenyls	1,000ppm (0.1%)
6	PBDE : Polybrominated Biphenyl Ethers	1,000ppm (0.1%)
7	DEHP : Bis (2-ethylhexyl) phthalate	1,000ppm (0.1%)
8	BBP : Butyl benzyl phthalate	1,000ppm (0.1%)
9	DBP : Dibutyl phthalate	1,000ppm (0.1%)
10	DIBP : Diisobutyl phthalate	1,000ppm (0.1%)

1. Reliability testing result

Reliability testing result	Applicable standard	Testing conditions	Duration	Failure
Room temp. operating life	EIAJ ED-4701/100(101)	Ta=25°C, If=Maxium rated current	1,000 h	0/25
Resistance to soldering heat	EIAJ ED-4701/300(301)	Pre-heating : 150 to 180°C 120s max. Operation heating : 230°C 40s max. Peak temperature : 260°C	2 times	0/25
Temperature cycling	EIAJ ED-4701/100(105)	Minimum rated storage temperature (30min) to Normal temperature (15min) to Maximum rated storage temperature (30min) to Normal temperature (15min)	5 cycles	0/25
Wet high temp. storage life	EIAJ ED-4701/100(103)	Ta=60±2°C, RH=90±5%	1,000 h	0/25
High temp. storage life	EIAJ ED-4701/200(201)	Ta=Maximum rated storage temperature	1,000 h	0/25
Low temp. storage life	EIAJ ED-4701/200(202)	Ta=Minimum rated storage temperature	1,000 h	0/25
Vibration, variable frequency	EIAJ ED-4701/400(403)	98.1m/s ² (10G), 100 to 2KHz sweep for 20min., XYZ each direction	2 h	0/10

2. Failure criteria

Item	Symbol	Condition	Failure Criteria
Luminous Intensity	I _V	5mA	Testing Min. Value < Standard Min. Value × 0.5
Forward Voltage	V _F	5mA	Testing Max. Value ≥ Standard Max. Value × 1.2
Reverse Current	I _R	V _R =5V	Testing Max. Value ≥ Standard Max. Value × 2.5
Cosmetic Appearance	-	-	Notable, decollation, deformation and cracking

Special notice to customers using the products and technical information shown in this data sheet

- 1) The technical information shown in the data sheets are limited to the typical characteristics and circuit examples of the referenced products. It does not constitute the warranting of industrial property nor the granting of any license.
- 2) For the purpose of product improvement, the specifications, characteristics and technical data described in the data sheets are subject to change without prior notice. Therefore it is recommended that the most updated specifications be used in your design.
- 3) When using the products described in the data sheets, please adhere to the maximum ratings for operating voltage, heat dissipation characteristics, and other precautions for use. We are not responsible for any damage which may occur if these specifications are exceeded.
- 4) The products that have been described to this catalog are manufactured so that they will be used for the electrical instrument of the benchmark (OA equipment, telecommunications equipment, AV machine, home appliance and measuring instrument).
The application of aircrafts, space borne application, transportation equipment, medical equipment and nuclear power control equipment, etc. needs a high reliability and safety, and the breakdown and the wrong operation might influence the life or the human body. Please consult us beforehand if you plan to use our product for the usages of aircrafts, space borne application, transportation equipment, medical equipment and nuclear power control equipment, etc. except OA equipment, telecommunications equipment, AV machine, home appliance and measuring instrument.
- 5) In order to export the products or technologies described in this data sheet which are under the “Foreign Exchange and Foreign Trade Control Law,” it is necessary to first obtain an export permit from the Japanese government.
- 6) No part of this data sheet may be reprinted or reproduced without prior written permission from Stanley Electric Co., Ltd.
- 7) The most updated edition of this data sheet can be obtained from the address below:
<http://www.stanley-components.com/en/>